



# Power MOSFETS

## DATASHEET

---

**LM20B30NGC3A**

N-Channel  
Enhancement Mode MOSFET

 Leadpower-semiconductor Corp., Ltd

 [sales@leadpower-semi.com](mailto:sales@leadpower-semi.com)

 (03) 6577339 FAX : (03) 6577229

 [www.leadpower-semi.com](http://www.leadpower-semi.com)



Quality Management Systems

ISO 9001:2015 Certificate

## N-Channel Enhancement Mode MOSFET

### Pin Description

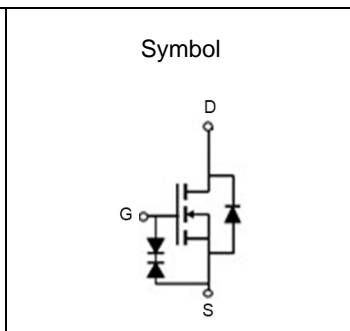
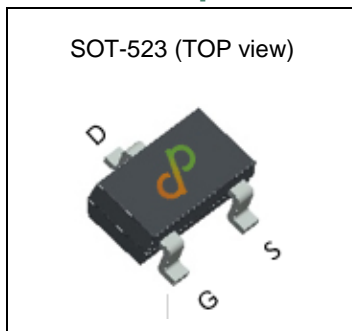

### Ordering Information

Symbol	N-Channel	Unit
$V_{DSS}$	<b>20</b>	<b>V</b>
$R_{DS(ON)-Max}$	<b>230</b>	<b>mΩ</b>
$I_D$	<b>0.87</b>	<b>A</b>

### Feature

- Reliable and Rugged
- ROHS Compliant & Halogen-Free
- ESD Protection

### Applications

- Small Signal Switch
- Load Switch

### Ordering Information

Orderable Part Number	Package Type	Form	Shipping	Marking
LM20B30NGC3A	SOT-523	Tape & Reel	3000 / Tape & Reel	0□□□

### Absolute Maximum Ratings (T<sub>J</sub>=25°C Unless Otherwise Noted)

Symbol	Parameter		N-Channel	Unit
$V_{DSS}$	Drain-Source Voltage		20	V
$V_{GSS}$	Gate-Source Voltage		±8	
$T_J$	Maximum Junction Temperature		150	°C
$T_{STG}$	Storage Temperature Range		-55 to 150	°C
$I_{DM}^{①}$	Pulse Drain Current Tested	$T_A=25^{\circ}C$	2.2	A
$I_D$	Continuous Drain Current	$T_A=25^{\circ}C$	0.87	A
		$T_A=70^{\circ}C$	0.7	
$P_D$	Maximum Power Dissipation	$T_A=25^{\circ}C$	0.28	W
		$T_A=70^{\circ}C$	0.18	

### Thermal Characteristics

Symbol	Parameter		Rating	Unit
$R_{\theta JA}^{②}$	Thermal Resistance-Junction to Ambient	Steady State	452	°C/W

Note ① : Max. current is limited by junction temperature.

Note ② : Surface Mounted on 1in<sup>2</sup> FR-4 board with 1oz.

## N-Channel Electrical Characteristics (T<sub>J</sub>=25°C Unless Otherwise Noted)

Symbol	Parameter	Test Conditions	Min.	Typ.	Max.	Unit
<b>Static Electrical Characteristics</b>						
<b>BV<sub>DSS</sub></b>	Drain-Source Breakdown Voltage	V <sub>GS</sub> =0V, I <sub>DS</sub> =250uA	20	-	-	V
<b>I<sub>DSS</sub></b>	Zero Gate Voltage Drain Current	V <sub>DS</sub> =16V, V <sub>GS</sub> =0V	-	-	1	uA
<b>V<sub>GS(th)</sub></b>	Gate Threshold Voltage	V <sub>DS</sub> =V <sub>GS</sub> , I <sub>DS</sub> =250uA	0.5	-	1	V
<b>I<sub>GSS</sub></b>	Gate Leakage Current	V <sub>GS</sub> =±8V, V <sub>DS</sub> =0V	-	-	±10	uA
<b>R<sub>DS(ON)</sub></b> <sup>③</sup>	Drain-Source On-state Resistance	V <sub>GS</sub> =4.5V, I <sub>DS</sub> =550mA	-	190	230	mΩ
		V <sub>GS</sub> =2.5V, I <sub>DS</sub> =450mA	-	234	305	
		V <sub>GS</sub> =1.8V, I <sub>DS</sub> =350mA	-	303	455	
<b>gfs</b>	Forward Transconductance	V <sub>DS</sub> =5V, I <sub>DS</sub> =550mA	-	1.7	-	S
<b>Dynamic Characteristics</b> <sup>④</sup>						
<b>C<sub>iss</sub></b>	Input Capacitance	V <sub>GS</sub> =0V, V <sub>DS</sub> =10V, Freq.=1MHz	-	43	-	pF
<b>C<sub>oss</sub></b>	Output Capacitance		-	9	-	
<b>C<sub>rss</sub></b>	Reverse Transfer Capacitance		-	6	-	
<b>td(ON)</b>	Turn-on Delay Time	V <sub>GS</sub> =4.5V, V <sub>DS</sub> =10V, I <sub>D</sub> =2A, R <sub>GEN</sub> =6Ω	-	1.2	-	nS
<b>t<sub>r</sub></b>	Turn-on Rise Time		-	25	-	
<b>t<sub>d(OFF)</sub></b>	Turn-off Delay Time		-	14	-	
<b>t<sub>f</sub></b>	Turn-off Fall Time		-	15	-	
<b>Q<sub>g</sub></b>	Total Gate Charge	V <sub>GS</sub> =2.5V, V <sub>DS</sub> =10V I <sub>D</sub> =1A	-	1.1	-	nC
<b>Q<sub>g</sub></b>	Total Gate Charge	V <sub>GS</sub> =4.5V, V <sub>DS</sub> =10V, I <sub>D</sub> =1A	-	2	-	
<b>Q<sub>gs</sub></b>	Gate-Source Charge		-	0.3	-	
<b>Q<sub>gd</sub></b>	Gate-Drain Charge		-	0.3	-	
<b>Source-Drain Characteristics</b>						
<b>V<sub>SD</sub></b> <sup>③</sup>	Diode Forward Voltage	I <sub>SD</sub> =0.35A, V <sub>GS</sub> =0V	-	0.75	1.1	V
<b>t<sub>rr</sub></b>	Reverse Recovery Time	I <sub>F</sub> =1A, V <sub>R</sub> =0	-	9	-	nS
<b>Q<sub>rr</sub></b>	Reverse Recovery Charge	diF/dt=100A/μs	-	1	-	nC

Note ③ : Pulse test (pulse width≤300us, duty cycle≤2%).

Note ④ : Guaranteed by design, not subject to production testing.

## N-Channel Typical Characteristics

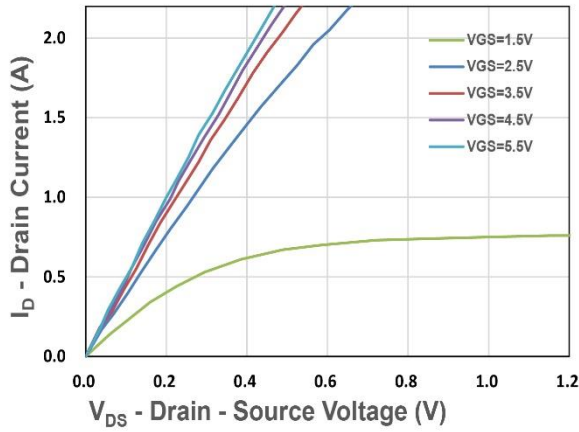

Figure 1. Output Characteristics

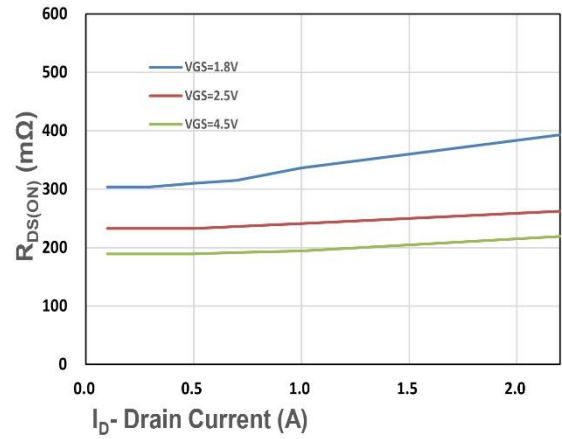

Figure 2. On-Resistance vs. ID

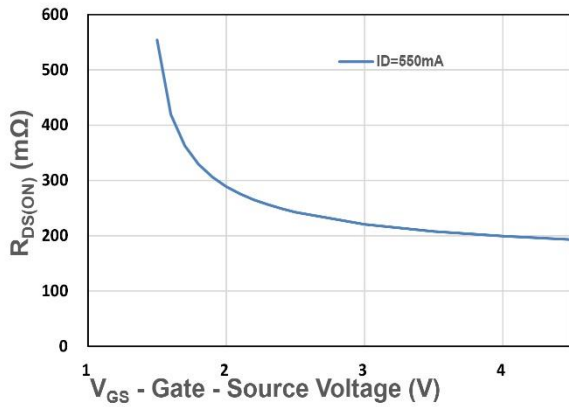

Figure 3. On-Resistance vs. VGS

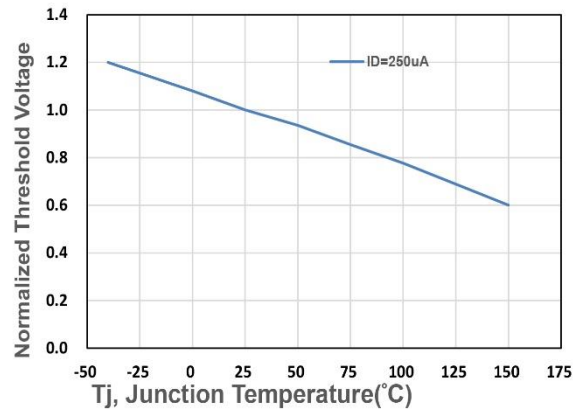

Figure 4. Gate Threshold Voltage

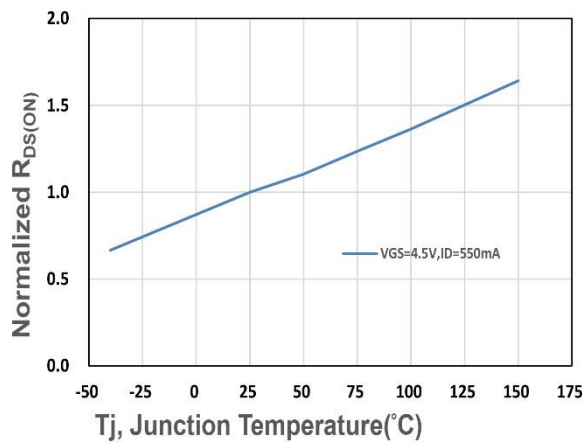

Figure 5. Drain-Source On Resistance

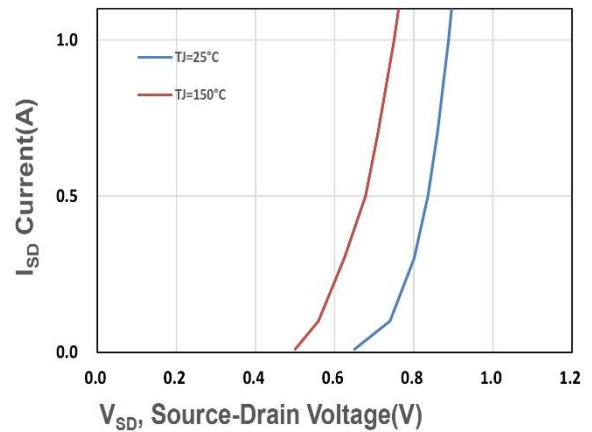

Figure 6. Source-Drain Diode Forward

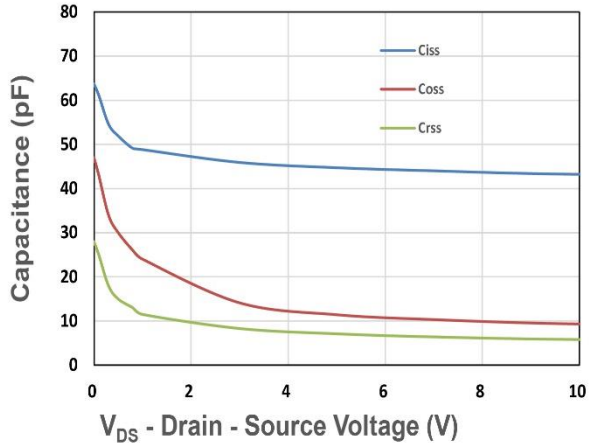

Figure 7. Capacitance

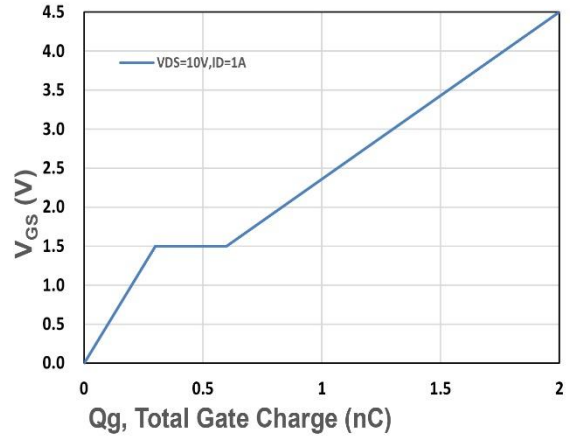

Figure 8. Gate Charge Characteristics

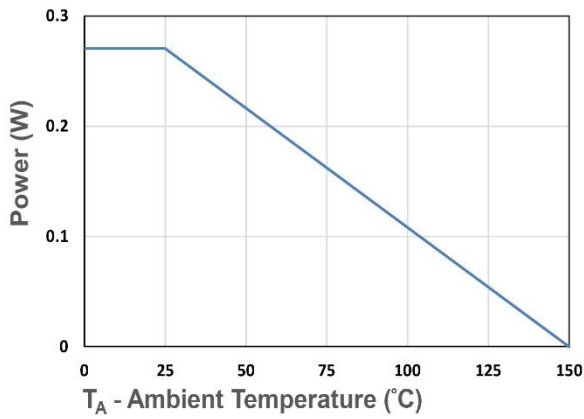

Figure 9. Power Dissipation

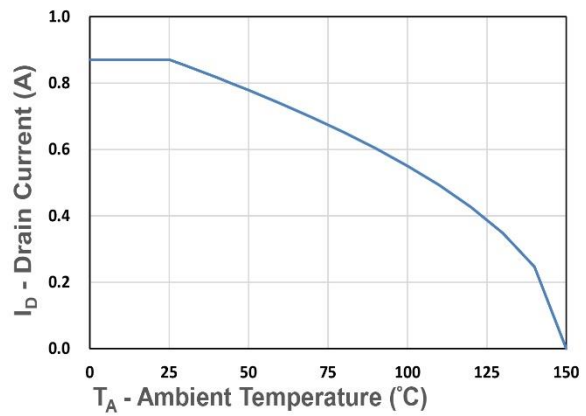

Figure 10. Drain Current

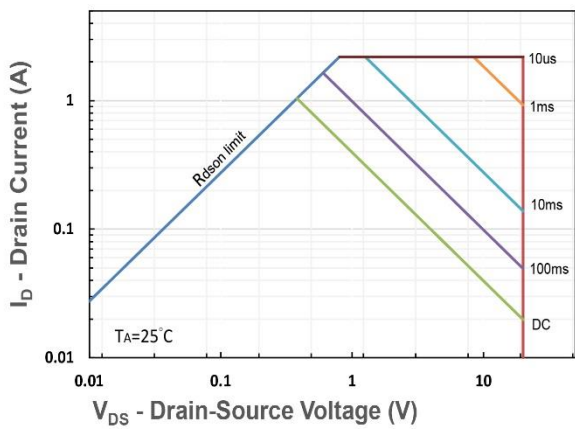

Figure 11. Safe Operating Area

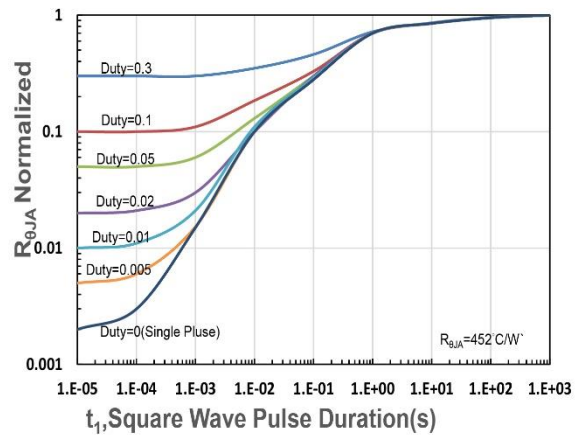

Figure 12.  $R_{\theta JA}$  Transient Thermal Impedance